

Part Number: PT347-47160

Kit Contents

Item #	Quantity Reqd.	Description
1	1	Convenience Net
2	1	Hardware Bag

Hardware Bag Contents

Item #	Quantity Reqd.	Description
1	1	LH Bracket Hook
2	1	RH Bracket Hook
3	1	LH Trim Panel Cover
4	1	RH Trim Panel Cover
5	1	LH Button Anchor
6	1	RH Button Anchor

Additional Items Required For Installation

Item #	Quantity Reqd.	Description

Conflicts

None

Recommended Tools

Personal & Vehicle Protection	Notes
None	
Special Tools	Notes
None	
Installation Tools	Notes
Screwdriver	Phillips
Trim Panel Removal Tool	
Special Chemicals	Notes
None	

General Applicability

All Prius Models

Recommended Sequence of Application

Item #	Accessory

Vehicle Service Parts (may be required for reassembly)

Item #	Quantity Reqd.	Description

Legend

 **STOP:** Damage to the vehicle may occur. Do not proceed until process has been complied with.

 **OPERATOR SAFETY:** Use caution to avoid risk of injury.

 **CAUTION:** A process that must be carefully observed in order to reduce the risk of damage to the accessory/vehicle and to ensure a quality installation.

 **TOOLS & EQUIPMENT:** Used in Figures calls out the specific tools and equipment recommended for this process.

 **REVISION MARK:** This mark highlights a change in installation with respect to previous issue.

 **SAFETY TORQUE:** This mark indicates that torque is related to safety.

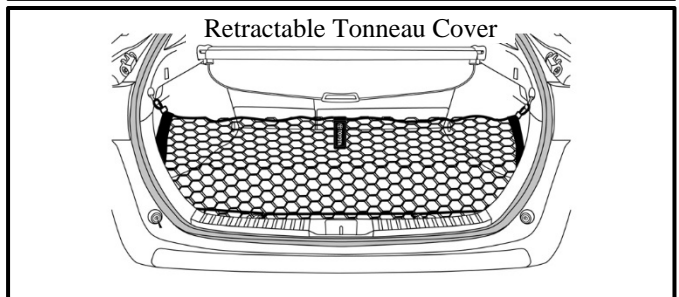
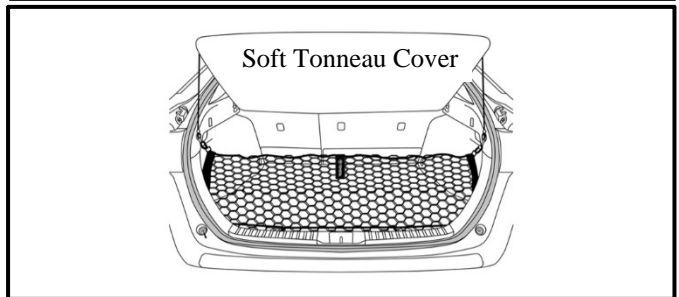

Care must be taken when installing this accessory to ensure damage does not occur to the vehicle. The installation of this accessory should follow approved guidelines to ensure a quality installation.

These guidelines can be found in the "Accessory Installation Practices" document.

This document covers such items as:-

- Vehicle Protection (use of covers and blankets, cleaning chemicals, etc.).
- Safety (eye protection, rechecking torque procedure, etc.).
- Vehicle Disassembly/Reassembly (panel removal, part storage, etc.).
- Electrical Component Disassembly/Reassembly (battery disconnection, connector removal, etc.).

Please see your dealer for a copy of this document.

Procedure

Parts Required

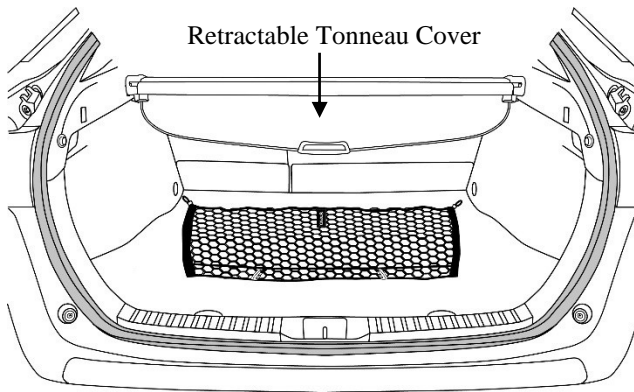
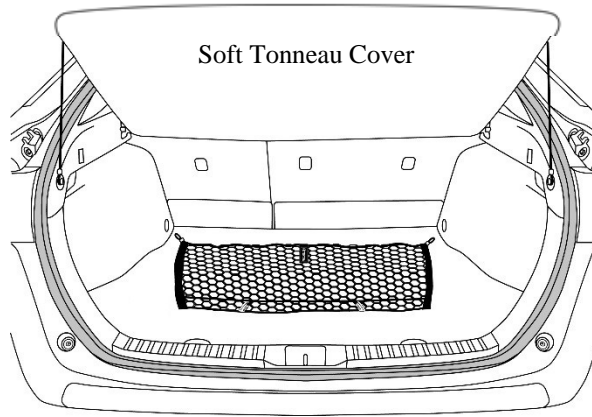
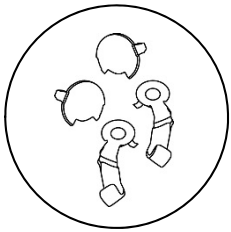
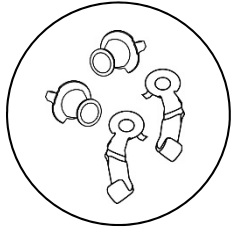

Tools Required

Trim Panel Removal Tool

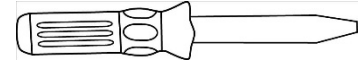

Screwdriver, Phillips

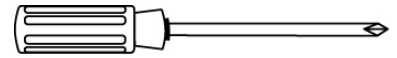

1

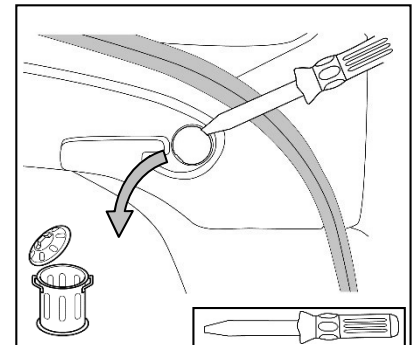
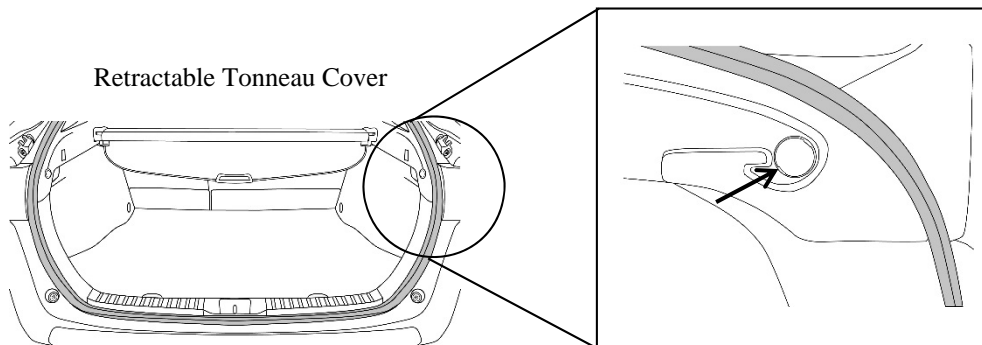
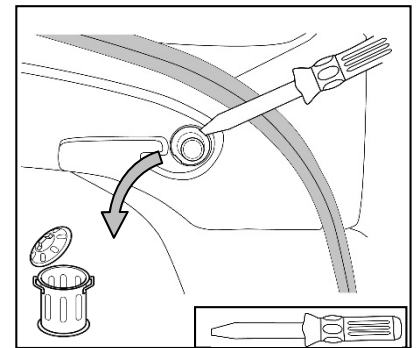
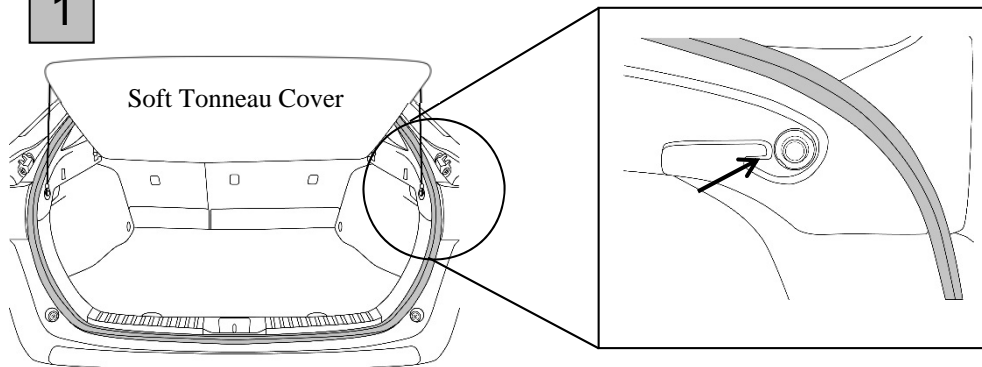

Repeat on Driver Side

Issue: C 01/19/2016

Procedure

2

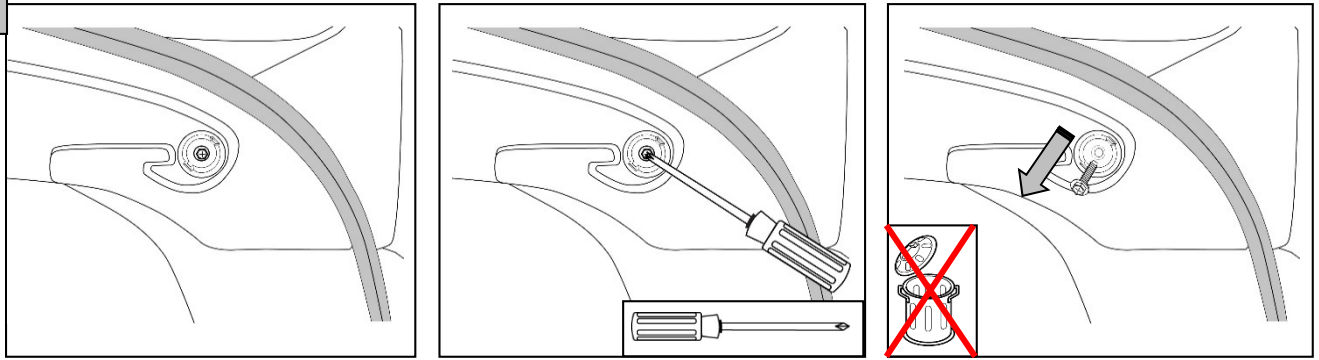

Retain Screws – Repeat on Driver Side

3

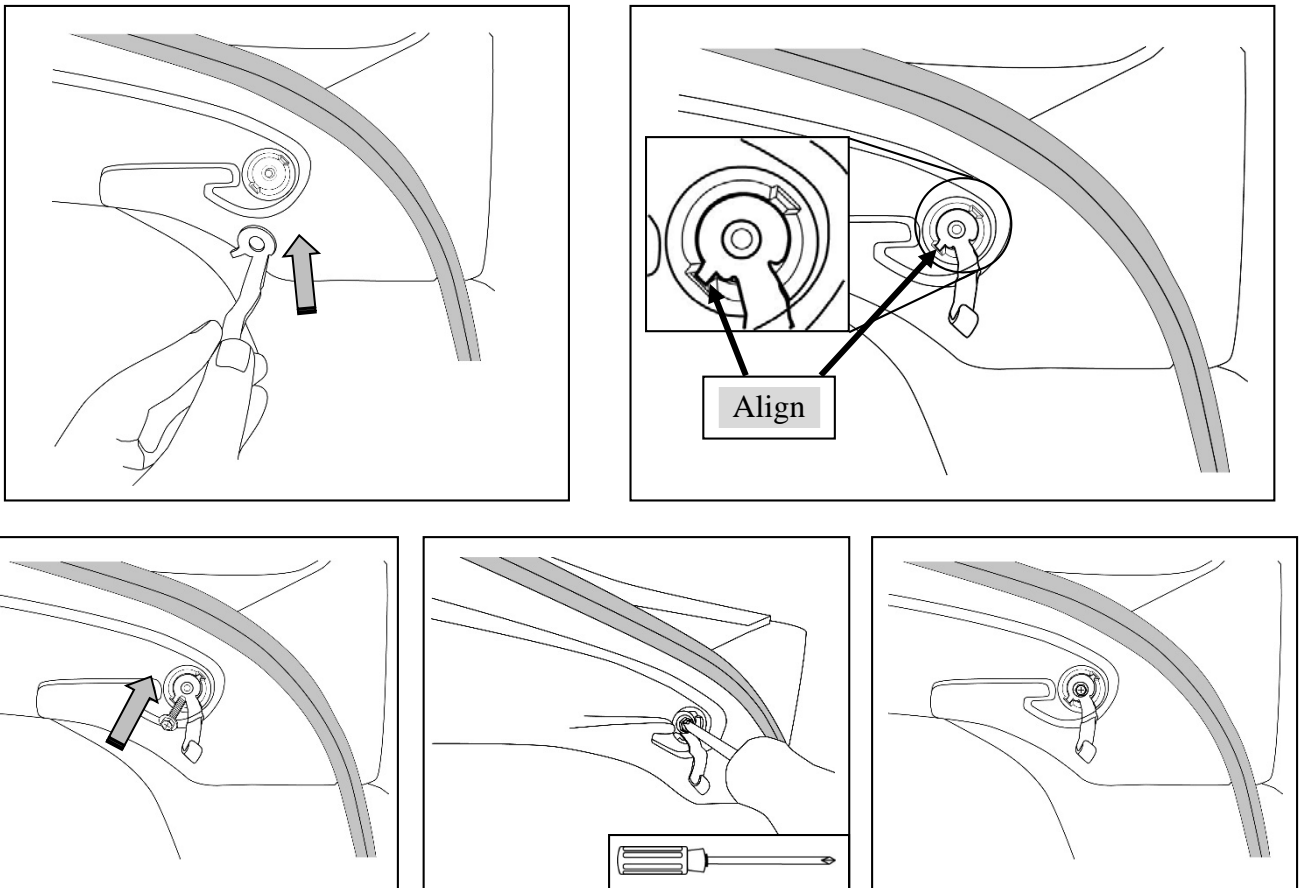

Repeat on Driver Side

Procedure

4

Soft Tonneau Cover

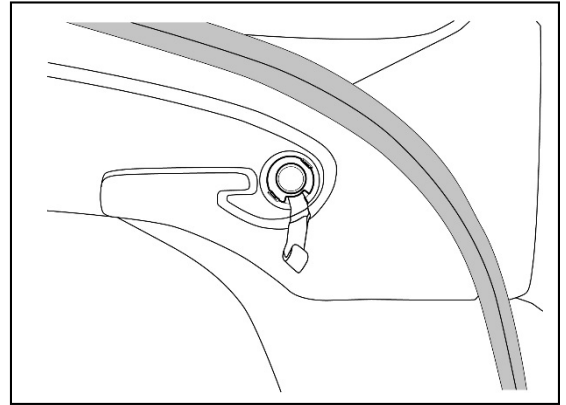
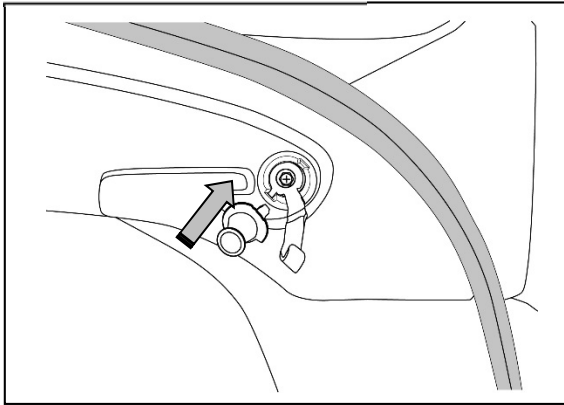

Retractable Tonneau Cover

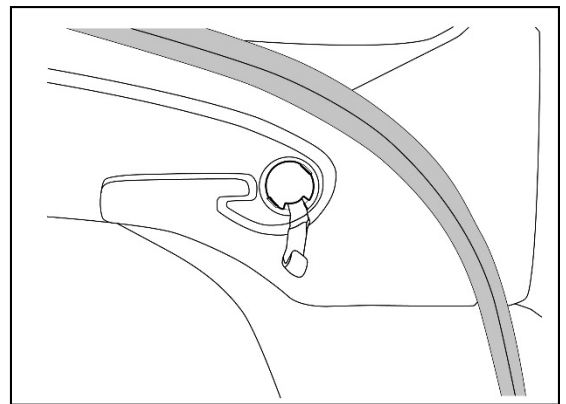
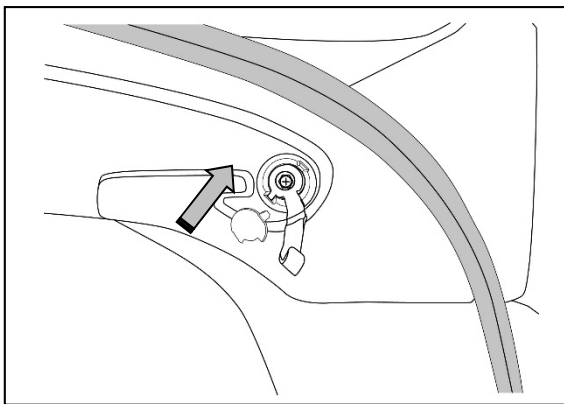

Repeat on Driver Side

5

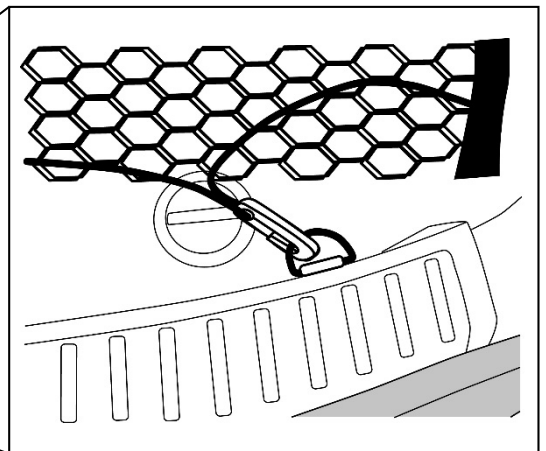
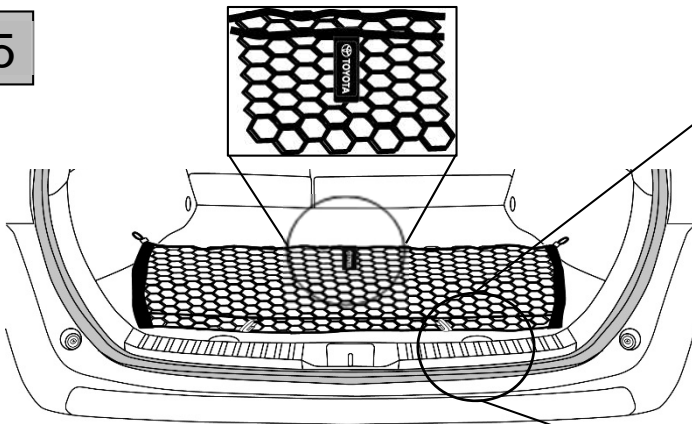

Repeat on Driver Side

Procedure

6

Reattach Soft Tonneau Cover Cord

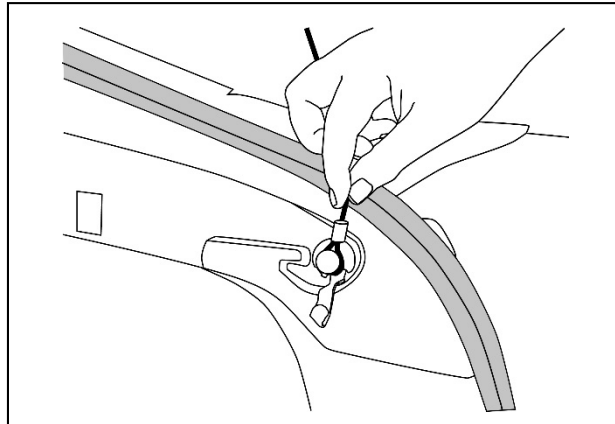

Repeat on Driver Side

7

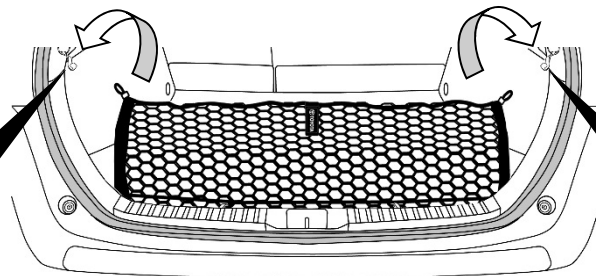

Soft Tonneau Cover

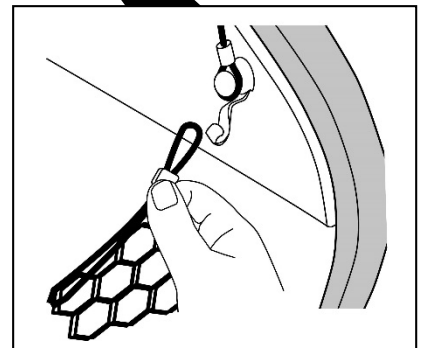
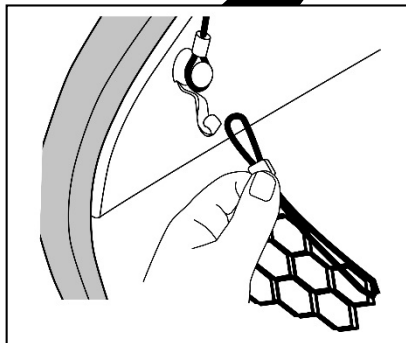

Retractable Tonneau Cover

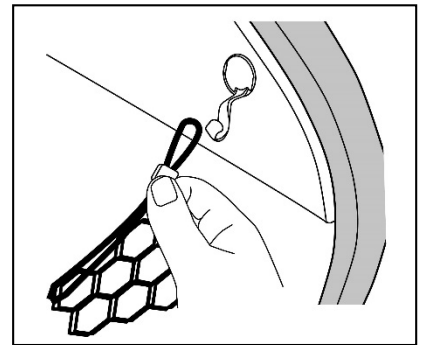
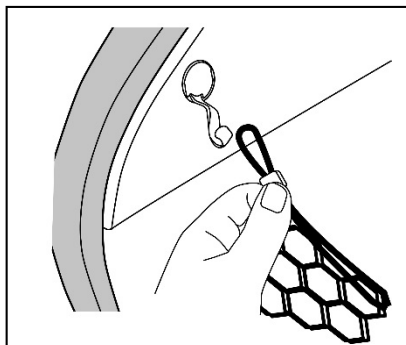

Procedure

8

Soft Tonneau Cover

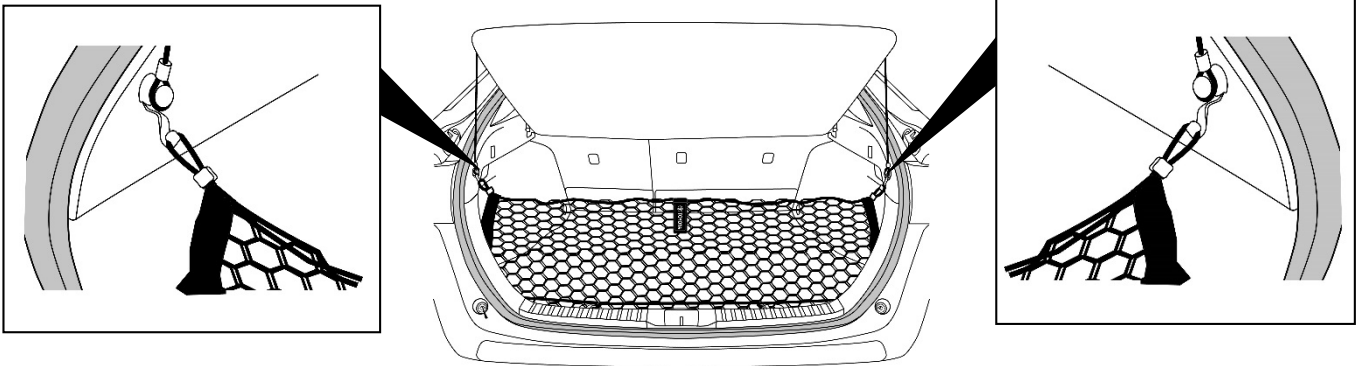

Retractable Tonneau Cover

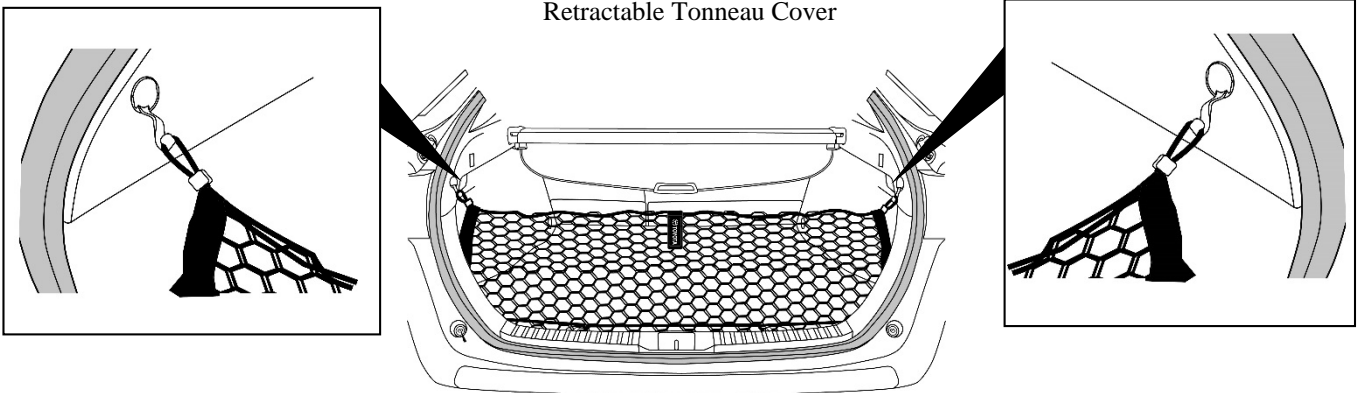

Checklist - these points **MUST** be checked to ensure a quality installation.

Accessory Function Checks

- Confirm that the net is attached properly to the anchor points in the vehicle.

Confirm net handle is facing toward the rear of the vehicle.

Confirm upper loops at the top of the net are attached to the hooks of the vehicle.

Vehicle Function Checks

- Vehicle trunk operation

Confirm vehicle trunk opens and closes without interference from Cargo Net.

- Tonneau cover operation

Confirm tonneau cover opens and closes freely without interference from cargo net or hook.

Vehicle Appearance Check

- After accessory installation and removal of protective cover(s), perform a visual inspection.

Ensure no damage (including scuffs and scratches) was caused during the installation process. (For PPO installations, refer to TMS Accessory Quality Shipping Standard.)